



警告

- 未成年人需成人陪伴操作。
- 使用軟氣槍時需配戴護目鏡。
- 粗心或濫用軟氣槍容易造成自己及他人身體上的傷害。
- 不能將槍口對人或動物。
- 操作軟氣槍前請確實研讀使用說明書。
- 買家及玩家購買,使用軟氣槍需遵守各國當地法令與規定。

TW



WARNING

- Product is intended for adults 18 years and older.
- Wear proper eye protection while shooting.
- Misuse may cause injury or death.
- The muzzle of an airsoft gun should never be pointed at someone to cause injury.
- Read this entire manual to ensure proper usage.
- Buyers and users should obey the laws and rules of the local authority.

EN



ATENCIÓN

- Si el jugador o jugadores tienen menos de 18 años se les requerirá ir acompañados de un mayor de edad que se responsabilice del menor en todo momento.
- Durante la práctica del Airsoft, es obligatorio llevar gafas de protección ocular acorde a las normativas vigentes en todo momento.
- El uso descuidado o indebido del Airsoft puede causar fácilmente daños a sí mismo y a los que le rodean.
- No se debe apuntar a personas o animales.
- Lea bien los manuales que acompañan las réplicas antes de empezar a usarlas para practicar Airsoft.
- Los poseedores de réplicas de Airsoft deben seguir estrictamente las leyes y regulaciones locales vigentes en el país de residencia o uso de las mismas, e informarse debidamente en los puntos de venta o autoridades del país antes de comprar y utilizar cualquier réplica de airsoft.

ES



ATTENTION

- Ce produit est réservé aux utilisateurs de 18 ans et plus.
- Toujours porter des protections oculaires adaptées lors de l'utilisation du produit.
- La mauvaise utilisation de ce produit peut causer des blessures graves ou la mort.
- Ne jamais pointer le canon de la réplique sur quelqu'un pour causer des blessures.
- Lire attentivement le mode d'emploi avant d'utiliser ce produit.
- L'acheteur et l'utilisateur de ce produit doivent se conformer aux lois du pays qui réglementent l'usage et la possession de répliques airsoft.

FR



警告

- 対象年齢18才以上。
- 弾を発射する際は、必ず安全なゴーグルを装着してください。
- 不用意に引き金を引くと非常に危険です。
- 50m以内は危険です。
- 取扱説明書は最後まで必ずお読み下さい。
- 購入者及び販売者は、エアガンの使用及び所有に関するすべての現地法律に準ずる。

JP

G&G
SINCE 1986
ARMAMENT

TAIWAN **ChangHua**
(Headquarters)
Sales Dept.
Technology Dept.

Tel : +886-4-798-9000 Fax : +886-4-798-9900
No.999, Zhonghua Rd. Shengang Township, Changhua County 50952, Taiwan (R.O.C.)
sales@guay2.com, b2b@guay2.com PR Dept. | pr@guay2.com
support@guay2.com

G2-202204-02-多



GPM1911 IWO JIMA Limited Version

TW 說明書 | 01-02 EN Operating Instructions | 03-04 ES Instrucciones de operación | 05-06
FR Mode d'emploi | 07-08 JP 取扱説明書 | 09-10



G&G
SINCE 1986
ARMAMENT



The Battle of Iwo Jima (19 February – 26 March 1945) was a major battle in which the United States Marine Corps and Navy landed on and eventually captured the island of Iwo Jima from the Imperial Japanese Army (IJA) during World War II. The American invasion, designated Operation Detachment, had the purpose of capturing the island with its two airfields: South Field and Central Field.

The Japanese Army positions on the island were heavily fortified, with a dense network of bunkers, hidden artillery positions, and 18 km (11 mi) of tunnels. The American ground forces were supported by extensive naval artillery and had complete air supremacy provided by U.S. Navy and Marine Corps aviators throughout the battle. The five-week battle saw some of the fiercest and bloodiest fighting of the Pacific War.

The Japanese combat deaths numbered three times the number of American deaths, but uniquely among Pacific War Marine battles, the American total casualties (dead and wounded) exceeded those of the Japanese. Of the 21,000 Japanese soldiers on Iwo Jima at the beginning of the battle, only 216 were taken prisoner, some of whom were captured only because they had been knocked unconscious or otherwise disabled. Most of the remainder were killed in action, but it has been estimated that as many as 3,000 continued to resist within the various cave systems for many days afterwards until they eventually succumbed to their injuries or surrendered weeks later.

Despite the bloody fighting and severe casualties on both sides, the American victory was assured from the start. Overwhelming American superiority in numbers and arms as well as complete air supremacy—coupled with the impossibility of Japanese retreat or reinforcement, as well as sparse food and supplies—permitted no plausible circumstance in which the Japanese could have ultimately won the battle.

[零件說明]



⚠ 未射擊前請關上保險。



[彈匣設置]

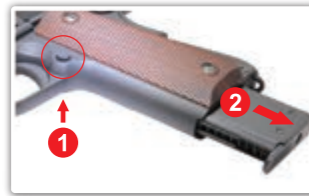

⚠ 強烈建議使用G&G生產之高精度BB彈延長產品壽命，避免影響產品保固。

[射擊預備]



[基礎保養]

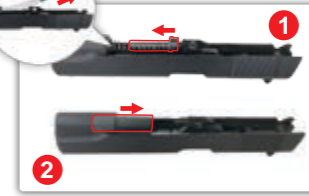

⚠ 請勿使用CRC-556、WD40或任何具有腐蝕性的潤滑油。

[彈道調整]

⚠ 若調整內腔時仍有BB彈停留在內腔內，則需射擊數發後調整的效果才會正確。

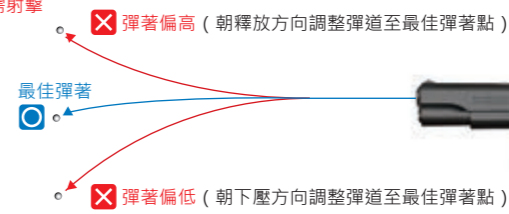

[COMPONENT]



⚠ Always keep the safety on if not ready to shoot.



Safety On
The gun will not fire.



Firing Mode
Single shot.

[FIRING]



Insert the magazine.



Switch off the safety.



To engage the hammer, pull the slide backward



1. Press the grip safety down.
2. Pull the trigger.

[MAINTENANCE]



1. Push the magazine release down.
2. Remove the magazine.



1. Hold the slide backward as shown.
2. Push in the slide stop.
3. Pull the slide stop out.
4. Push the slide forward.

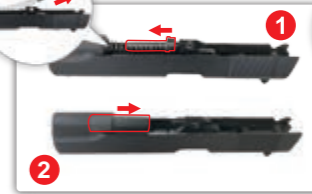

1. Remove the recoil spring and the guide rod.
2. Remove the recoil spring plug.



1. Flip the slide over and turn the barrel plug counter clock-wise to remove it.
2. Remove the barrel.

⚠ Never use CRC-556, WD40, or other corrosive lubricants.

[SETTING MAGAZINE]



Safety on.



1. Push the magazine release down.
2. Remove the magazine.



Load BB pellets and fill gas into the magazine.

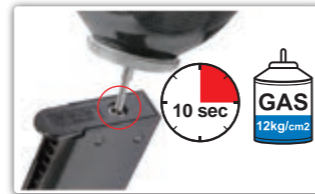

⚠ It is strongly recommended to use G&G Armament high precision BB's only. Using low quality BB pellets may shorten product life and void product warranty.

[HOP-UP ADJUSTMENT]



⊗ Too much Hop-up. (Turn the adjust lever toward Normal)

Best Position.

⊗ Not enough Hop-up. (Turn the dial toward Hop)

⚠ The hopup may require some shots to settle if a BB was inside the chamber during the adjustment.



[COMPONENTES]



⚠ Siempre coloque en modo seguro si no está listo para disparar.



Modo seguro
La réplica no dispara



Semi Auto
Disparo sencillo

[AJUSTES DE CARGADOR]



Modo seguro.



1. Apretar el botón del liberador de cargador.
2. Remueva el cargador.



Llenar el cargador con balines.



Llenar el cargador con Green Gas por 10 segundos.

⚠ Es altamente recomendado el uso de balines de precisión de G&G solamente. Usando balines de baja calidad puede acortar la vida del producto y eliminar la garantía.

[DISPARO]



Inserte el cargador.



Quite el seguro.



Para martillar la pistola, jale la corredera hacia atrás.



1. Presione el seguro en la empuñadura.
2. Apriete el gatillo.

[MANTENIMIENTO]



Libre el cargador.



1. Sostenga la corredera hacia atrás como desmostrado en la foto.
2. Empuje la palanca del retenedor de la corredera.
3. Saque la palanca del retenedor de la corredera.
4. Empuje la corredera hacia adelante.

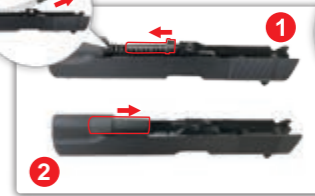

1. Retire la guía del muelle recuperador y el muelle recuperador.
2. Retire el tapón del muelle recuperador.



1. Retire el bushing del cañón.
2. Retire el cañón interior.

⚠ Nunca use CRC-556, WD40 u otro lubricante corrosivo.

[AJUSTES HOP-UP]

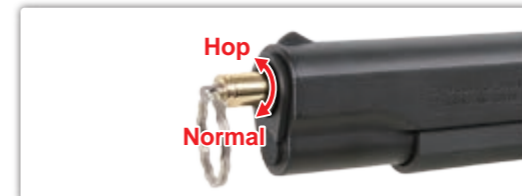

⊗ Mucho Hop-up (Gire el dial a normal).
○ Dirección correcta.
⊗ No mucho hop-up (Gire el dial a Hop).

⚠ El Hop Up puede requerir de algunos disparos para que se asienten por si algún BB haya quedado dentro de la cámara durante el ajuste.



[COMPOSANTS]



⚠ Toujours garder la sécurité active si vous n'êtes pas prêt à tirer.



Sécurité
Ne tire pas



Semi Auto
Tir coup par coup

[UTILISATION DU CHARGEUR]



Activez la sécurité.



1. Appuyez sur l'arrêteur de chargeur.
2. Retirez le chargeur.



Chargez les billes dans le chargeur.

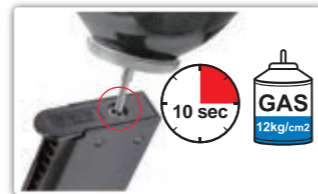

Remplissez le chargeur de gaz.

⚠ Il est fortement recommandé d'utiliser uniquement des billes de haute précision G&G Armament. L'utilisation de billes d'une qualité inférieure réduira la durée de vie de votre réplique et annulera la garantie.

[TIR]



Insérez le chargeur.



Désactivez la sécurité.



Pour engager le chien, tirez la glissière en arrière.



1. Maintenez enfoncée la pédale de sûreté.
2. Appuyez sur la queue de détente.

[MAINTENANCE]



1. Appuyez sur l'arrêteur de chargeur.
2. Retirez le chargeur.



1. Maintenez la culasse en arrière.
2. Poussez sur l'arrêteur de culasse.
3. Retirez l'arrêteur de culasse.
4. Retirez la culasse vers l'avant.



1. Retirez le ressort et son guide.
2. Retirez l'embout du ressort.

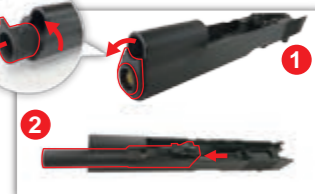

1. Retournez la glissière et tournez le manchon dans le sens antihoraire pour le retirer.
2. Retirez le canon.

⚠ N'utilisez jamais de CRC-556, WD40 ou tout autre lubrifiant corrosif.

[REGLAGE HOP-UP]

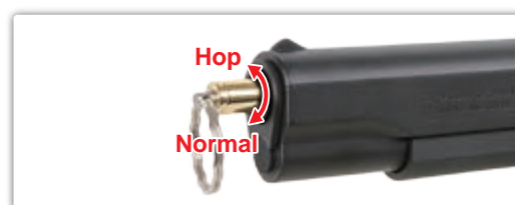

⊗ Trop d'effet hop-up (tournez vers Normal).

Position optimale.

⊗ Pas assez d'effet hop-up (tournez vers Normal).

⚠ Le hopup peut nécessiter quelques tirs avant de faire effet surtout si une bille se trouvait dans la chambre lors de l'ajustement.

【構成要素】



⚠ 撃たないときは、常にセーフティにしてください。



セーフティオン
発射できません



セミアート
単発

【マガジン装着】



セーフティオン。



1. マガジンキャッチボタンを押してください。
2. マガジンを取り出してください。



フォアローを一番下まで下げて、BB弾投入口から、BB弾を1発ずつ入れる。注入バルブに、ガスポンペのノズルを合わせる。

⚠ 必ずG & G製の純正BB弾をご使用ください。他社製BB弾は故障を誘発する恐れがあります。

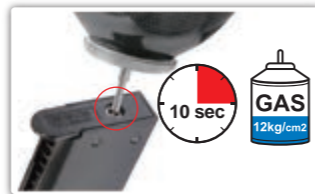

10 sec
GAS
12kg/cm²

【発射】



マガジンを予め準備しておきます。



セフティレバーをセミアートの位置にします。



スライドを後方の止まる所まで引いたら一気に手を離してください。すると、スライドが自動的に前進します。



1. グリップセーフティを押さえてください。
2. トリガーに入さし指をかけて手前に引きます。

【メンテナンス】



マガジンを外します。



1. (図のとおり)、スライドを後ろにずらして切り欠きをあわせませす。
2. スライドストップを押してください。
3. スライドストップを抜き取ります。
4. 前にずらしてスライドを抜きます。



1. リコイルスプリングとリコイルガイドロッドを外してください。
2. スプリングプラグを外してください。



1. パレルプラグを左に回して外してください。
2. パレルを外してください。

⚠ CRC-556、WD40または他の腐食性潤滑油を決して使わないでください。

【ホップアップ調整】



⊗ ホップアップのかけ過ぎ (ノーマル方向に回してください)。

ベストポジション

⊗ ホップアップの不足 (ホップ方向に回してください)。

⚠ チャンバー内にBB弾が残っていると調整がうまく出来ない場合があります。また、調整の際は数発撃って適正かどうかを確認してください。

GPM1911 IWO JIMA Limited Version Parts List

- GPM1911 GQI-A02-01** 下槍身模組 / Receiver Set / Recibidor de la pistola / Ens. corps / レシーバーセット
- GPM1911 GQI-A03-01** 滑套模組 / Slide Set / Conjunto de la corredora / Ens. glissière / スライドセット
- GPM1911 GQI-A04-01** GAS彈匣 / GAS Magazine / Cargador de GAS / Chargeur GAZ / GAS マガジン
- GPM1911 GFK-A10-02** 飛機座 / Cylinder Set / Conjunto de Cilindro / Ens. cylindre / シリンダーセット
- GPM1911 GFK-A12-02** 飛機頭 / Nozzle Set / Set de Boquilla / Ens. nozzle / ノズルセット
- GPM1911 GFK-A13-01** EU 槍管模組 / Barrel Set / Conjunto de Cañón / Ens. canon / バレルセット
- GPM1911 GFK-A17-01** US 槍管模組 / Barrel Set / Conjunto de Cañón / Ens. canon / バレルセット

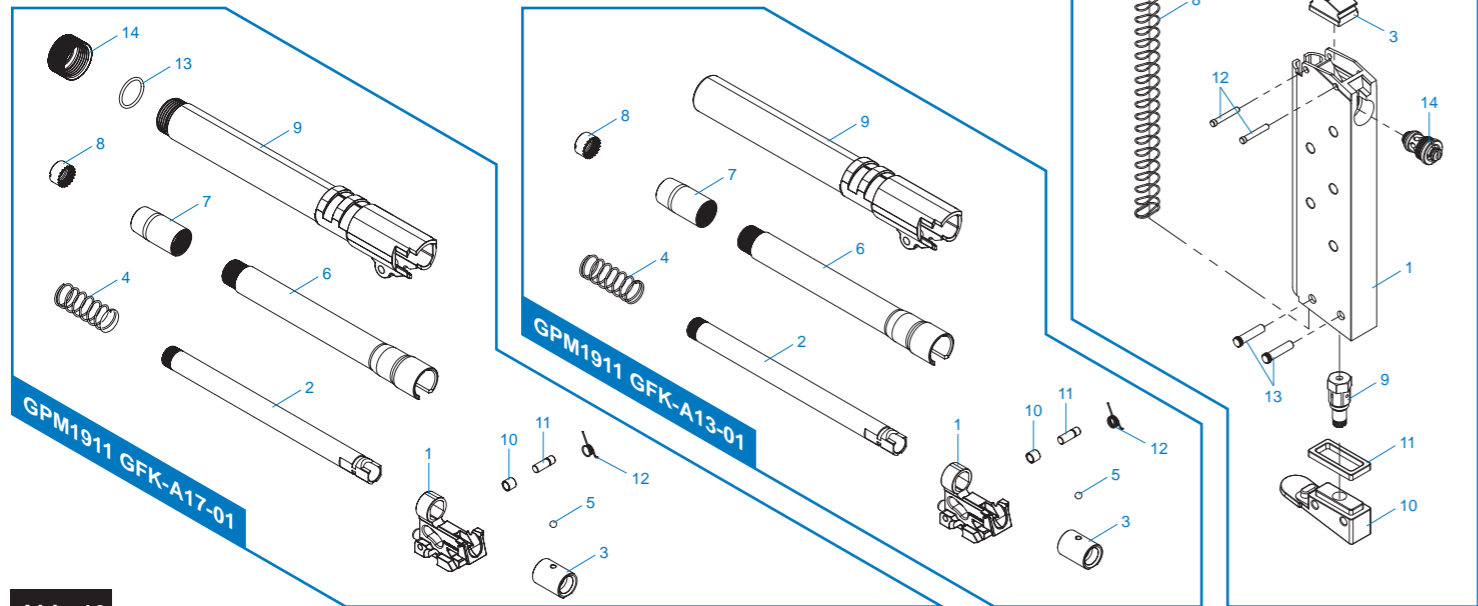

- TW** 細部分解圖中的所有零件都可向怪怪貿易有限公司訂購。
- EN** The grouped parts may all be purchased from the G&G Support Department.
- ES** Todas las partes pueden ser compradas en el departamento de Soporte de G&G.

- FR** Ces pièces détachées sont disponibles à l'achat auprès du service après-vente G&G.
- JP** グループ・パーツのすべては、G&Gサポートから購入できます。
- E-Mail: support@guay2.com

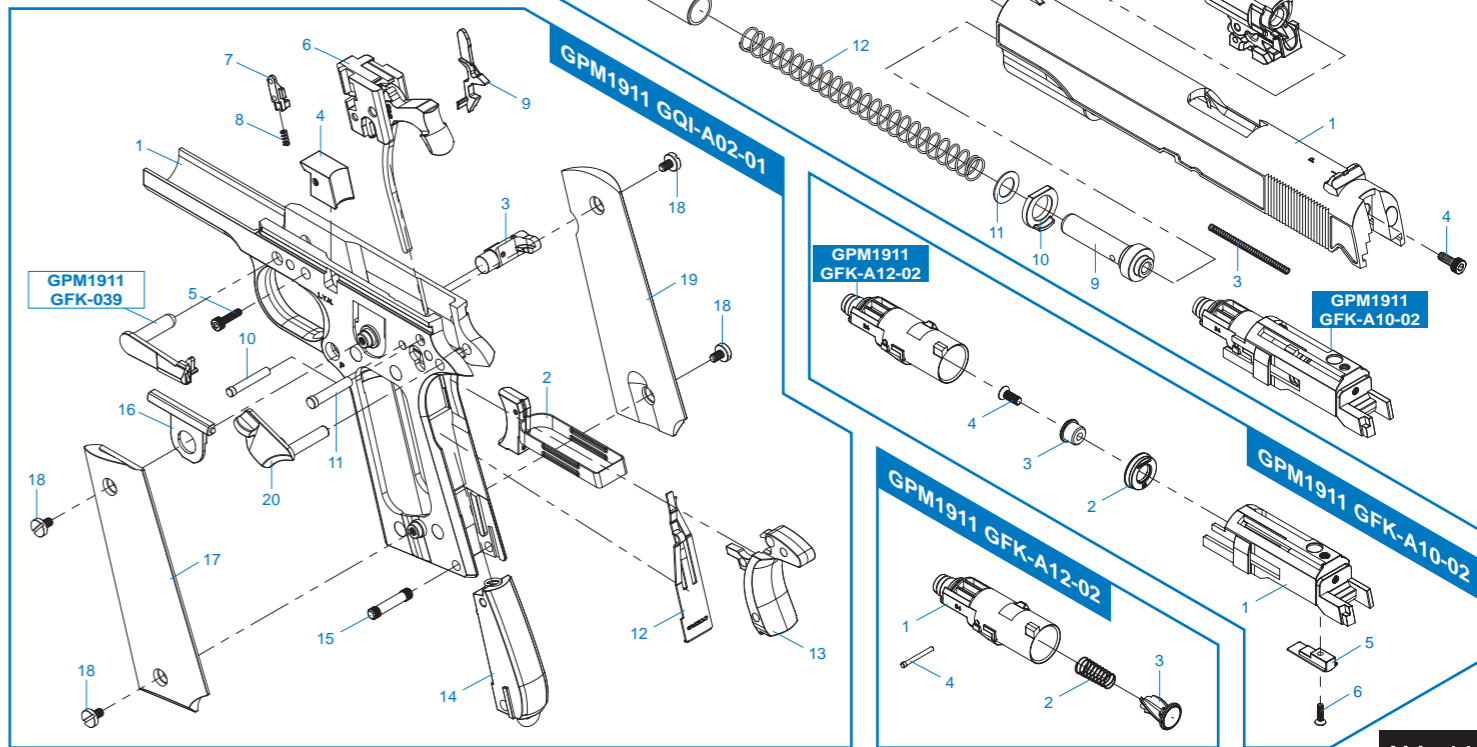





即使你只是開玩笑對他人射擊，你也必須為他人與公物受到的傷害負完全的責任。請在法規的範圍內玩射擊遊戲。
You may be liable for damaging public or personal property or for injuring a person or an animal even if you only meant to shoot as a "practical joke". Always observe good manners and enjoy fun sport shooting.



不要將槍口指向人、動物或者造成第三人的傷害、危險。
Never direct the muzzle towards a person, animal or in any direction. That may cause harm or damage to the third party.



Usted puede ser responsable por daño de propiedad pública o privada al herir a una persona o animal incluso sin que fuese intencional o como una "broma pesada". Siempre tenga buenos modales y disfrute de la diversión de tiro deportivo.



Nunca dirija el cañón hacia una persona, un animal o en cualquier dirección. Puede causar daño o perjuicio a la terceros.



攜帶槍枝時，請將槍口套上安全套，關上保險位置，並把槍放入槍盒或槍袋中。
When you carry the air gun, attach the safety cap, set the selector lever to the safety position and always put the air gun in a case or bag.



私自拆解或改裝軟氣槍會造成危險，甚至會有違法的可能性。Disassembling or modifying the gun may adversely affect the performance and make it dangerous. It would also void the warranty.



Quando transporte la pistola, utilice una cobertura de cañón, coloque la pistola en modo seguro y siempre ponga la pistola en una bolsa o una caja.



Al modificar o desmontar la pistola puede afectar el rendimiento de la réplica y convertirlo en algo peligroso. "Puede estar en contra de la ley".



安全規範：
1. 關保險
2. 移除彈匣
Safety procedures:
1. Set the selector lever to the safety position.
2. Remove the magazine.



看槍口確認是否有BB彈滯留於槍管中是十分危險的。你的眼睛可能會被BB彈打傷，有失明的可能性。
Looking into the muzzle is extremely dangerous regardless of BB's having been loaded or not. If you get hit in the eye by a BB pellet, you may in worst case, lose your eye sight.



Procedimientos de Seguridad:
1. Coloque el selector en modo seguro.
2. Quite el cargador.



Mirar dentro el cañón es extremadamente peligroso a pesar de que los balines no hayan sido cargados. Si recibe un golpe directo en el ojo por un balin puede perder su vista permanentemente.



請選擇一個周邊沒有人和車的安全地點玩軟氣槍。
Select a safe place for operating the air gun, avoid places where people and cars are around.



射擊時不留意是十分危險的。不要將手指放在扳機上，除非你已取下安全套，準備開始射擊。
Pulling the trigger carelessly is extremely dangerous. Never put your finger on the trigger unless the safety cap is removed and you are ready to shoot a target.



Seleccione un lugar seguro para usar la pistola de aire, evite lugares donde se encuentren personas y coches alrededor.



Activar el gatillo sin cuidado es extremadamente peligroso. Nunca ponga el dedo en el gatillo a menos que la cobertura del cañón haya sido retirada y esté preparado para disparar al objetivo.



當在玩射擊遊戲或練習射擊時，請佩戴護目鏡，並注意彈跳物。最重要的不要傷害到周邊其他的人。
When shooting the air gun for target practice or in a game situation, you and all participants must wear safety goggles or other eye protection gear. Please pay attention to ricochets and third parties around you.



有些情況是在取下彈匣後發現還有BB彈滯留在槍身內，所以取下彈匣後請對空中或安全的地方射擊，無殘留後再套上安全套。
There may be cases where some BB's remain in the gun after the magazine has been removed. After removal of the magazine, direct the muzzle towards a safe direction and pull the trigger to confirm that there are no BB's remain in the gun, then attach the safety cap.



Al disparar las pistolas de aire en prácticas de tiro o en juegos, usted y todos los participantes deberán llevar gafas de seguridad u otras gafas protectoras. También preste atención al rebote. Es muy importante prestar atención no solo a los participantes sino también a terceros.



Puede haber casos en los balines se queden dentro de la pistola después de que el cargador haya sido retirado. Después de la extracción del cargador, dirija la boca del cañón hacia una dirección segura y apriete el gatillo para confirmar no haya quedado ningún balin dentro de la pistola, por último coloque la cobertura del cañón.

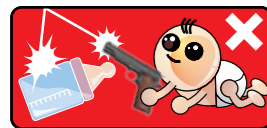

將槍口套上安全套，放入槍袋或槍盒中，並且放在孩童取不到的地方。
Always attach the safety cap to the muzzle, remove the battery and store the air gun in a case or bag and at a place that is out of reach by children.



射擊以外的時間，為避免BB彈造成意外危險及防止灰塵掉入槍管，請確實將槍口套上安全套，當槍管套上安全套時，不要扣扳機。
Make sure to put the barrel and safety cap on the muzzle, except when you are shooting. Do this to prevent accident, discharge of BB's and also for dust protection purpose. Never pull the trigger while the barrel and the safety cap is attached.

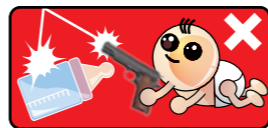



Siempre utilice una cobertura de cañón, retire la batería y almacene el rifle de aire en una caja o bolsa. Fuera del alcance de los niños.





Asegúrese de colocar siempre la cobertura de cañón en la bocacha, a excepción de cuando esté disparando. Para evitar accidentes por disparo de balines accidentales y proteger el rifle contra el polvo. Nunca tire del gatillo mientras la cobertura del cañón este en el barril.

 Vous pouvez être tenu responsable pour tout dommage de propriété publique ou personnelle, ou blessure sur une personne ou un animal. Faites preuve de fair-play pour profiter pleinement de l'Airsoft.

 Ne jamais pointer le canon de la réplique sur quelqu'un ou quelque chose pour causer des blessures ou des dommages.

 弾を発射する時やゲームなどの場合は、跳弾にも注意し、ゴーグルなどの眼の保護具を本人と参加者全員が必ず装着して行ってください。(参加者以外の第三者に弾が当たらないように十分注意ください。)

 エアガンで人や動物を狙ったり、撃ったりしないでください。標的を撃つ時以外は銃口に保護キャップを必ず装着してください。

 Mettre le capuchon de sécurité sur le cache-flamme, le sélecteur de tir sur la position sécurité et la réplique dans un sac lors de son transport.

 Désassembler ou modifier la réplique vous même peut affecter défavorablement ses performances, la rendre dangereuse et vous mettre hors la loi.

 エアガンを持ち歩く場合は、銃口に保護キャップをして、セレクトラーレバーをセーフティの位置にし、必ずケースやバッグに入れて運んでください。

 このエアガンは、最適性能、操作性を考慮して製造されています。むやみな分解、改造は、危険性を誘発したり性能を著しく損なう場合がありますので、絶対にお止めください。

 Procédures de sécurité:
1. Mettre le sélecteur de tir sur la position sécurité.
2. Retirer le magazine.

 Regarder dans le canon est extrêmement dangereux même s'il ne reste plus de billes dans la réplique. Si vous êtes touché à l'œil par une bille, vous risquez de perdre la vue.

 安全手順
1.切り替えレバー（セレクトラーレバー）をセーフティの位置にする。
2.マガジンを取り外す。

 銃口は、弾が入っている入っていないにかかわらず、絶対にのぞかないでください。BB弾が眼に当たった場所、最悪失明の恐れがあり大変危険です。

 Choisissez un endroit sûr pour utiliser la réplique, et évitez tout endroit entouré d'automobile ou de personne.

 Presser la queue de détente sans aucune précaution est extrêmement dangereux. Ne déposez jamais votre doigt sur la queue de détente si vous n'avez pas au préalable retiré le capuchon de sécurité et si vous n'êtes pas prêt à tirer.

 エアガン撃つ際は、安全に配慮し、人や動物又は危険な場所には向けしないでください。また、周囲に人がいるような場所での射撃は絶対にしないでください。

 標的に向けて発射する時以外は、引き金に指をかけないでください。引き金に指をかけた状態では、何らかのはずみで引き金を引いてしまう恐れがあり大変危険です。

 Lors de l'utilisation de la réplique, tout participant se doit de porter des lunettes de protection. Faites attention au ricochet des projectiles et aux passants.

 Dans certains cas il est possible que des billes soient restées dans la réplique après avoir retiré le magazine. Lorsque le magazine est retiré, pointez votre réplique dans une direction sans danger pour autrui et tirez pour vous assurer qu'il ne reste pas de billes à l'intérieur, puis mettez le capuchon de sécurité sur le cache-flamme.

 たとえイタズラつもりでも、共有物や他人の財産を撃って破損させたり、人や生き物を撃って怪我をさせたりすると、器物破損罪や傷害罪などで処罰される場合があります。

 マガジンを抜いてもガン内部に弾が残っている場合があります、不用意に引き金を引くと弾が発射され大変危険です。マガジンを抜いた後、銃口を安全な方向に向けて撃ち、弾が残っていない事を確認してから、銃口に保護キャップをして保管してください。

 Toujours mettre le capuchon de sécurité sur le cache-flamme, retirer la batterie et garder la réplique dans un sac à l'abri des enfants.

 Assurez-vous de mettre le bouchon de sécurité sur le cache-flamme, sauf si vous tirez évidemment. Procédez ainsi pour éviter tout accident et protéger la réplique de la poussière.

 対象年齢以外の子供がイタズラをして怪我などを起こさないように、必ず銃口に保護キャップをしてケースやバックにいれて子供が手の届かない所に保管してください。

 万が一の暴発を防ぐと共に防塵のために、発射時以外は必ず銃口に保護キャップを装着してください。