

# GC300 S/L INSTRUCTION MANUAL



## WARNING !!

- Adult supervision required.
- May be hazardous up to 50 meters.

- Stop shooting when the battery power is low.
- Do not adjust the motor without authorization or by certified technician.
- Always wear eye protection when using this product.
- Misuse or careless handling of this product may cause injury.

- This product is intended for users 18 years or older.
- Read all instructions before using this product.
- The buyer and the user of this product shall adhere to all local laws regulating the usage and the ownership of airsoft guns.

### FOLDING STOCK

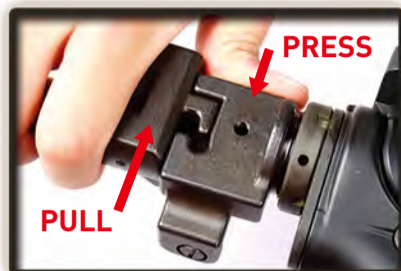

Press the stock base with the thumb and pull up.



Fold the stock to the left side of the gun.

### UNJAM



Remove the magazine.

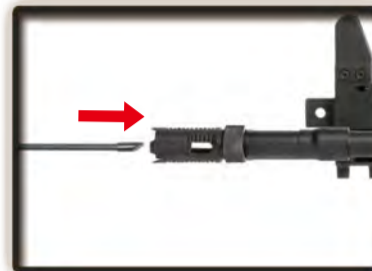

Return the hop up dial to normal position and insert the cleaning rod from the lead edge of the inner barrel.



Be sure to have the rod facing down and reaching to the end to remove clogged pellets.

### TROUBLE SHOOTING



Adjust screw when the gear noise becomes shrilly.

Use a screwdriver to adjust the screw at the bottom of the grip.



No operation

Check the wire set contact on the motor.



No operation

Make sure the battery is fully charged and wires are properly connected.

### FRONT SIGHT ADJUSTMENT



Use the front sight adjustment tool.

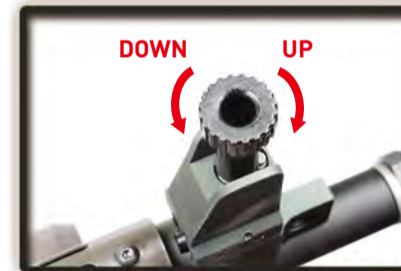

Turning clockwise: To correct high shots. Turning counterclockwise: To correct low shots.

### REAR SIGHT ADJUSTMENT



**SMALL HOLE**  
Used for precision firing.



**LARGE HOLE**  
Used for full automatic firing.



**WINDAGE KNOB**  
(left / right adjustment)

### MOVABLE PARTS

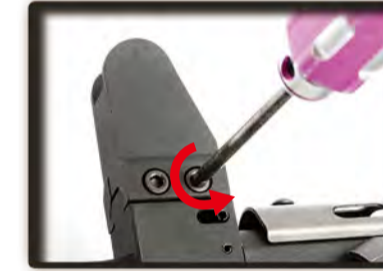

Unscrew and take the fixing screws off to remove the front sight.



Unscrew and take the fixing screws off to remove the rear sight.

### PARTS LIST

GC300-01	Flash suppressor set	GC300-14	Dust cover set
GC300-03	Outer barrel set (Long Type)	GC300-15	Lower receiver set
GC300-04	Outer barrel set (Short Type)	GC300-16	Charging handle
GC300-05	Inner barrel (Long Type)	GC300-17	Magazine catch set
GC300-06	Inner barrel (Short Type)	GC300-18	Rear receiver lock pin set
GC300-07	Handguard set	GC300-19	Selector lever set
GC300-08	Hop-Up rubber set	GC300-20	Wire set
GC300-09	Gear box set	GC300-21	Grip bottom plate set
GC300-10	Front sight set	GC300-22	Grip set
GC300-11	Hop-Up set	GC300-23	Motor set
GC300-12	Rear sight set	GC300-24	Magazine
GC300-13	Upper receiver set	GC300-25	Folding stock set

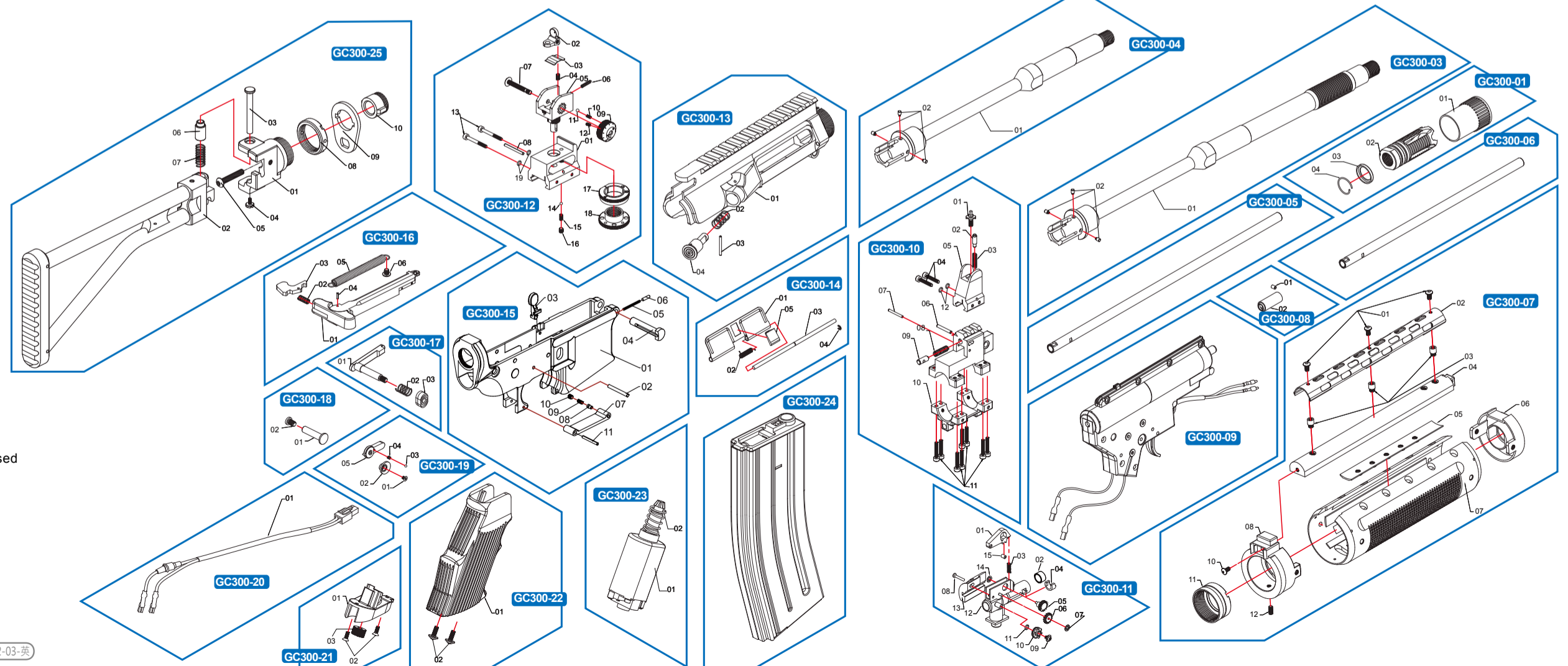

Sales Dept. | sales@guay2.com , b2b@guay2.com  
Technology Support Dept. | support@guay2.com  
PR Dept. | pr@guay2.com

▶ The grouped parts may all be purchased from the G&G Support Department.

▶ E-Mail: support@guay2.com

**Chang Hua** Headquarter  
Tel : +886-4-798-9000 Fax : +886-4-798-9900  
No.999, Zhonghua Rd. Shengang Township, Changhua County 50955, Taiwan (R.O.C.)

**Taipei**  
Tel : +886-2-2692-2000 Fax : +886-2-2692-4000  
11F-3., No.27, Lane 169, Kangning St. Shijr City, Taipei County 22180, Taiwan (R.O.C.)

Dealer