



GUAY2.COM

# 36 Service

- 36** 3 Systems, Offer Services In **6** Languages.
- 24** All warranty claims are dealt with within **24** hours.
- 36** Orders will be shipped within **36** hours of receiving payment.

## M1 Garand

NO.TGM-M1G-AEG-WNB-NCM

- TYPE | AEG
- LENGTH | 1103 mm
- WEIGHT | 3650 g
- MAGAZINE | 20 Rounds
- RECEIVER | Metal
- BEARING | 8 mm
- INNER BARREL | 510 mm
- BLOW BACK | NO
- VELOCITY | According to Local Regulation



### TAIWAN

**ChangHua (Head Quarter)** Tel : +886-4-798-9000 Fax : +886-4-798-9900  
No.999, Zhonghua Rd. Shengang Township, Changhua County 50952, Taiwan (R.O.C.)

**Taipei** Tel : +886-2-2692-2000 Fax : +886-2-2692-4000  
11F-3., No.27, Lane 169, Kangning St. Shijr City, Taipei County 22180, Taiwan (R.O.C.)

**Sales Dept.** sales@guay2.com, b2b@guay2.com  
**Technology Dept.** support@guay2.com  
**PR Dept.** pr@guay2.com

### U.S.A.

**Los Angeles** Tel : +1-626-581-0101 Fax : +1-626-581-1011  
1122 Coiner Court City of Industry, CA 91748 (U.S.A.)  
sales101@guay2.com

G2-201403-02-英



# M1 Garand

## Operating Instructions



- Stop shooting when the battery power is low.
- Do not adjust the motor without authorization or by certified technician.
- For maintenance, use the silicon oil on the air nozzle, do not use other types of corrosive oil.

WWW.GUAY2.COM

All G&G products are complied with CE and ROHS 2.0. G&G Armament is also certified manufacturer of ISO 9001.



# M1 Garand

## Operating Instructions



- Adult supervision required. Always wear safety goggles when using this product.
- Misuse or careless handling of this product may cause injury. May be hazardous up to 50 meters.

You may be liable for damaging public or personal property or for injuring a person or an animal. Always observe goodmanners and enjoy fun sport shooting.



Safety procedures :

1. Attach the safety cap to the muzzle.
2. Set the selector lever to the safety position.
3. Remove the magazine.
4. Remove the battery.



When shooting the air target practice or in a game situation, you and all participants must wear safety goggles or other eye protective gear. Also, pay attention to ricochets. It is very important to pay attention to third parties other than the participants.



When you carry the air gun, attach the safety cap, set the selector lever to the safety position and always put the air gun in a case or bag.



Select a safe place for operating the air gun, and avoid places where people and cars are around.



Always attach the safety cap to the muzzle, remove the battery, and store the air gun in a case or bag and at a place that is out of reach of children.



- This product is intended for users 18 years or older. Read all instructions before using this product.
- The buyer and the user of this product shall adhere to all local laws regulating the usage and the ownership of airsoft guns.

Never direct the muzzle towards a person or animal. This may cause harm or serious injury if an accident was to occur.



Looking into the muzzle is extremely dangerous! Regardless if BB's have been loaded or not. If you get hit in the eye by a BB, you may in worst case, lose your eye sight.



There may be cases where some BB's remain in the gun after the magazine has been removed. After removal of the magazine, direct the muzzle towards a safe direction and pull the trigger to confirm there are no BB's that remain in the gun. Set the selector lever to safety, then attach the safety cap.



Make sure to always put the safety cap on the muzzle when you are not shooting. Do this to prevent accident, discharge of BB's and also for dust protection purposes. Never pull the trigger while the safety cap is attached to the muzzle.



Activating the trigger carelessly is extremely dangerous. Never put your finger on the trigger unless the safety cap is removed and you are ready to shoot a target.



Disassembling or modifying the gun may adversely affect the performance of the gun and be dangerous. It also may Void the warranty and in some areas it might be against the Law.



# M1 Garand

Operating Instructions

## [ Contents ]

- 01 WARNING
- 03 CONTENTS
- 03 COMPONENTS
- 04 SAFETY MODE SETTING
- 04 BATTERY SETTING
- 05 LOADING THE MAGAZINE
- 06 REAR SIGHT ADJUSTMENT
- 06 BOLT HANDLE / HOP-UP ADJUSTMENT
- 07 FIRING / MAINTENANCE
- 08 TROUBLE SHOOTING
- 09 PARTS LIST



## [ Safety mode setting ]



### ⚠ ATTENTION

- Always make sure that the muzzle points into a safe direction.

## [ Battery setting ]

### ⚠ ATTENTION

- Use only the G&G battery purchased from your local dealer.



#### Step 1

Switch on safety.



#### Step 2

Open the battery cover.



#### Step 3

Connect the battery and insert into the stock.



#### Step 4

Close the battery cover.

# M1 Garand

## Operating Instructions

### [ Loading the magazine ]



ATTENTION

It is strongly recommended to only use G&G BB pellets. Using low quality BB pellets will damage your airsoft gun and void product warranty. • Only use flawless BBs. • Do not use the following BBs.

- 1 Diameter larger than 6mm. ← ∅ 6mm
- 2 With ridges or cracks.
- 3 Both halves not aligned.
- 4 Used, soiled.

#### Step 1



Press the magazine release to remove the magazine.

#### Step 2

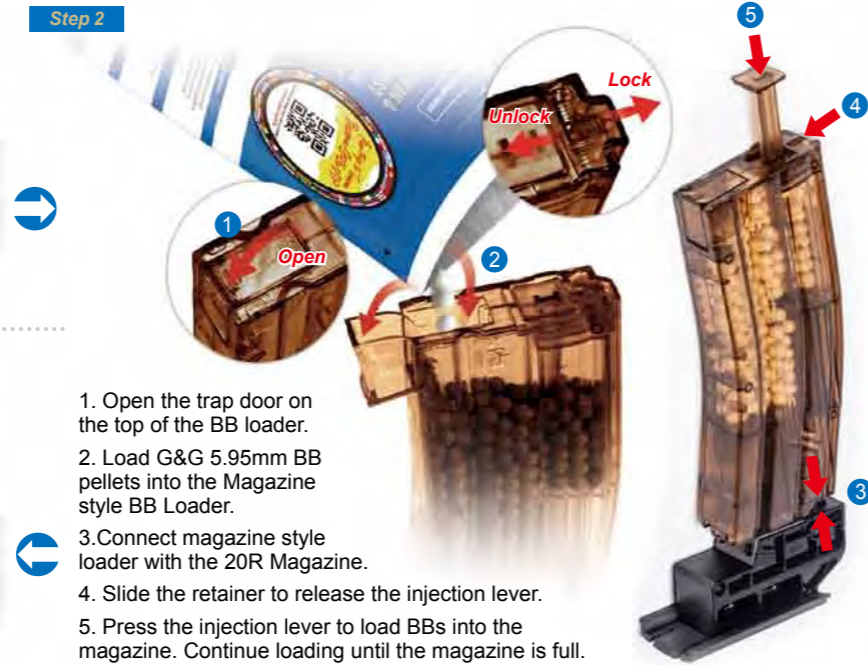

1. Open the trap door on the top of the BB loader.
2. Load G&G 5.95mm BB pellets into the Magazine style BB Loader.
3. Connect magazine style loader with the 20R Magazine.
4. Slide the retainer to release the injection lever.
5. Press the injection lever to load BBs into the magazine. Continue loading until the magazine is full.

Magazine Style 420R BB Loader [ Optional Parts ]

#### Step 3



Insert the magazine into the rifle.

### [ Rear sight adjustment ]

#### [ ELEVATION ADJUSTMENT KNOB ]

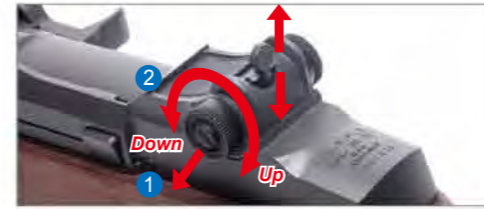

1. Pull and turn the knob to adjust the sight.
2. Turning clockwise : To correct high shots. Turning counter-clockwise: To correct low shots.

#### [ WINDAGE ADJUSTMENT KNOB ]

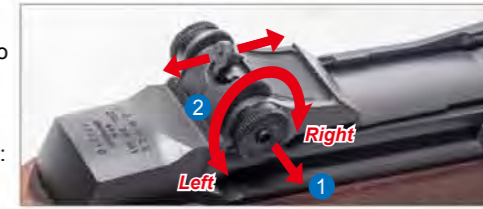

1. Pull and turn the knob to adjust the sight.
2. Turning clockwise : To correct the shots leaning to the left. Turning counter-clockwise: To correct the shots leaning to the right.



### [ Bolt Handle & Hop-up Adjustment ]



Pull the bolt handle backwards. Turn hop-up dial to adjust to the BB pellets' ideal flight pattern. The hop-up dial can only be turned a certain amount. Turning too much will damage the unit.



#### ATTENTION

- Never hold the gun sideways as the BB pellets will curve right or left. This is due to the HOP-UP system.

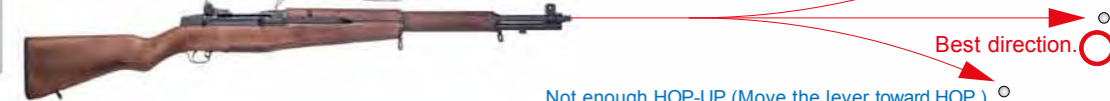

Not enough HOP-UP. (Move the lever toward HOP.) Or too much HOP-UP. (Return the lever toward NORMAL.)

#### ATTENTION

- Be careful not to catch your fingers in the dummy bolt.



# M1 Garand

## Operating Instructions

### [ Firing ]

#### After Operation

- Remove the magazine, direct the muzzle into a safe direction then fire the gun in semi-auto mode for a few shots. Switch on safety.
- Always disconnect the battery and attach the protective cap whenever you do not operate the air gun.



- Step 1** Make sure insert the magazine upwards and into the rifle until it clicks.
- Step 2** Remove the protective cap only when you are ready for firing the gun.
- Step 3** Switch off safety and you are now ready to fire.

Make sure no dirt gets into the chamber to avoid clogging of BB pellets. The hop up may take 200 to 300 rounds to remove the excessive silicone oil, this is the normal operation for the gun.



#### ⚠ ATTENTION

Never use CRC-556, WD40 or other corrosive lubricant.

**When BB pellets are clogged** If BB pellets are clogged, remove them and apply a few drops of G&G silicone oil into the chamber from the magazine entrance. Apply G&G silicone oil for 0.5 to 1 sec, to obtain smooth continuous firing.

### [ Maintenance ]

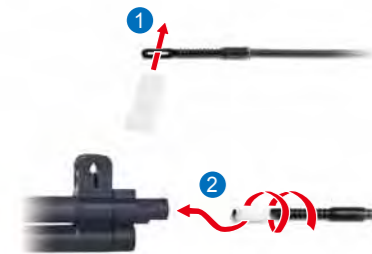

- Before you clean the inner barrel, make sure the hop up is turn to normal position.
- Take a piece of cotton cloth about 1 inch by 0.5 inch and insert one end of the cloth into the hole of the tip of cleaning rod and wrap it around the tip.
- Apply a drop of silicone oil or Teflon oil on the cloth and insert the cleaning rod into inner barrel.
- Check the cloth and repeat above steps until no dirt on the cloth.



- Return the hop up dial to the Normal position and insert the cleaning rod from the lead edge of the barrel.
- To remove clogged BB's, carefully insert the cleaning rod inside the barrel with the flat tip facing down as shown below.



### [ Trouble shooting ]

SYMPTOM	POTENTIAL	CORRECTIVE
No operation at all	Selector lever is set to safety.	Set the selector lever to Semi.
	Battery is not charged.	Charge the battery.
	Battery connector is disconnected.	Connect the connector.
	The + and - of battery connector is reverse.	Connect the connector correctly(check the fuse)
Although motor is revolving, no pellet can be fired	Expired motor life (50,000 to 60,000 rounds) or poor electrical connection.	Replace the dead motor (can be purchased from local dealer or directly G&G). Check and repair the contacts.
	Pellets are clogged inside the magazine.	Insert the charging rod into the magazine and move up and down a few times to remove clogged pellets.
	Pellets are clogged in the chamber.	Remove clogged pellets using the cleaning rod.
Shooting distance becomes shorter	Faulty gear.	Prurchase the replacement gear from your dealer or G&G and repair.
	Damaged or worn chamber set.	Replace the replacement parts(Purchasing from your dealer or G&G).
	Damaged or worn piston set (O-ring,piston spring).	
	Something is jammed in the inner barrel.	Use the cleaning rod and clean the inner barrel.
	Faulty BB pellets (too small or heavy).	Use the genuine G&G Pellets.
	Shrotage of silicone oil.	Drops few drops of silicone oil from upper the chamber.
	Gear problem caused by too many blank firing.	Consult your dealer or G&G for overhaul maintenance, part replacement (gear,etc.) or repair.
Too loud operating noise		
Pellets being fallen out from barrel end	Damaged or worn chamber set.	Turn the hop adjustment lever toward Hop.
	No hop setting.	
If gun gets wet	Faulty BB Pellets (too small or heavy).	Use the G&G Pellets.
	Stop operation immediately, disconnect the battery, wipe off water from inside the main body and the battery. After completely dry, carry out trial firing. If the unit is not operational, please contact your local dealer for repair.	



# M1 Garand

Operating Instructions

## [ Parts list ]

- M1G - 01** Rear handguard retainer
- M1G - 02** Front barrel set
- M1G - 03** Bolt handle set
- M1G - 04** Trigger set
- M1G - 05** Front handguard set
- M1G - 06** Rear handguard set
- M1G - 07** Stock set
- M1G - 08** Gear box set
- M1G - 09** Motor set
- M1G - 10** Dummy Bolt Plate
- M1G - 11** Upper receiver set
- M1G - 12** Inner barrel
- M1G - 13** Outer barrel set
- M1G - 14** Rear sight set
- M1G - 15** Hop-up set
- M1G - 16** Bolt handle spring set
- M1G - 17** Stock Plate Set
- M1G - 18** Magazine

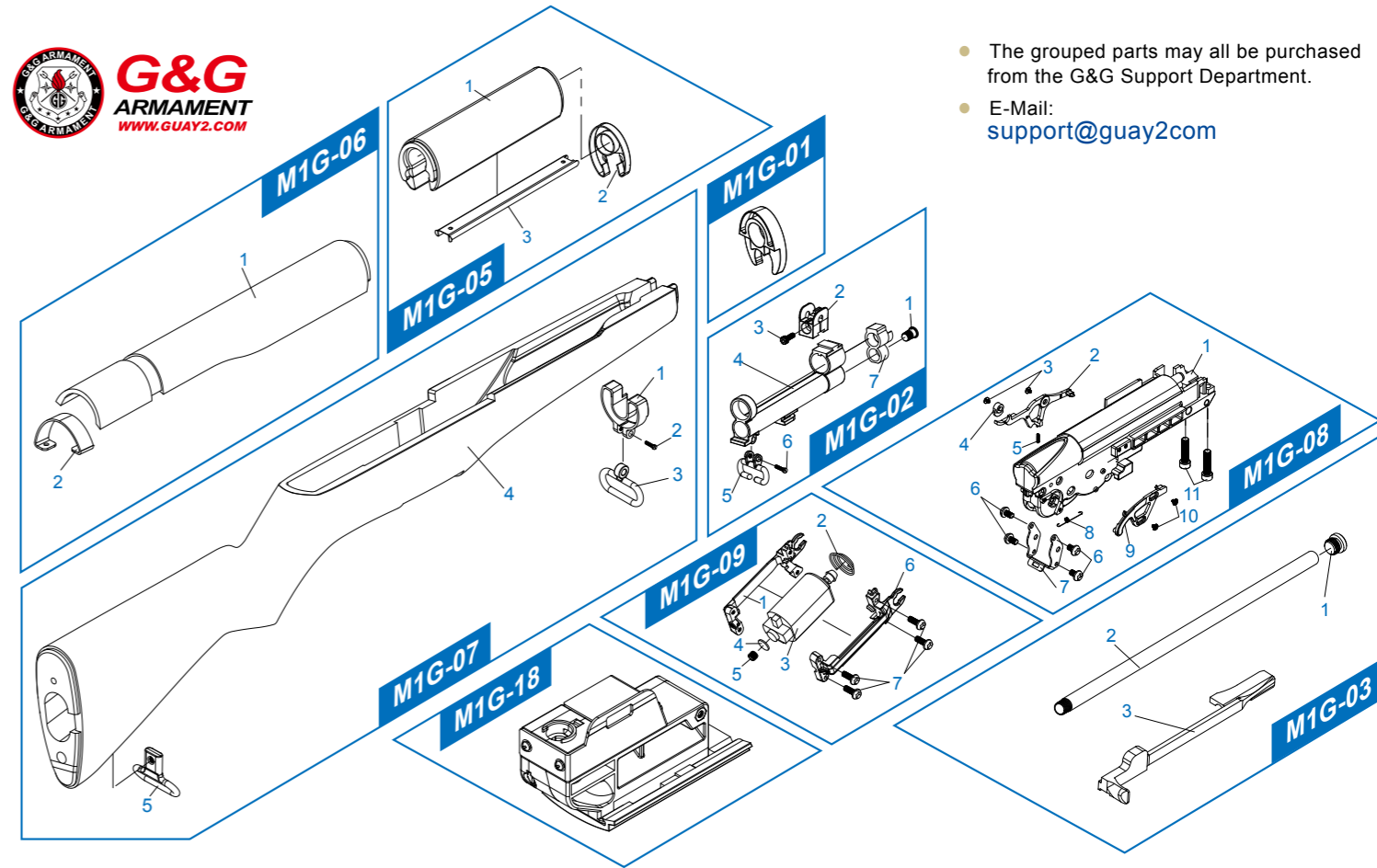
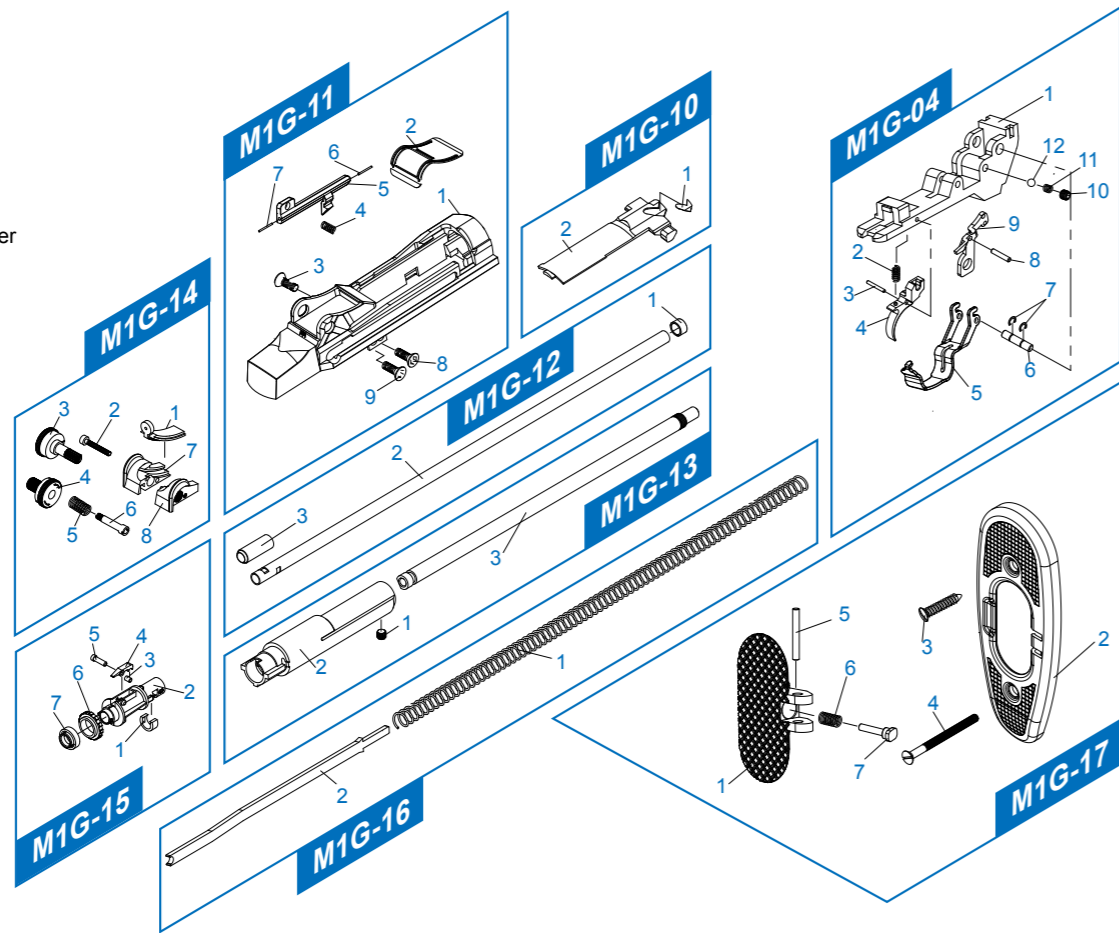

- The grouped parts may all be purchased from the G&G Support Department.
- E-Mail: [support@guay2.com](mailto:support@guay2.com)

