



Guay2tv



ggarmament



@ggarmament



@ggarmament

INSTRUCTION MANUAL

GC300 S/L

All G&G products are complied with CE and RoHS 2.0.
 G&G Armament is also a certified manufacturer of ISO 9001.



WARNING!

- Stop shooting when the battery power is low.
- Do not adjust the motor without authorization or by certified technician.
- This product is intended for users 18 years or older.
- Always wear eye protection when using this product.
- Misuse or careless handling of this product may cause injury.
- May be hazardous up to 50 meters
- Adult supervision required.
- Read all instructions before using this product.
- The buyer and the user of this product shall adhere to all local laws regulating the usage and the ownership of airsoft guns.

CHARGING & INSTALLING BATTERIES

CAUTION

1. Please use quality battery with the CE to avoid any unnecessary damage on the product.
2. Use recommended batteries only. Defected or low quality batteries might damage the product.
3. Remove the battery from the product when it is not in use.
4. Do not wet nor incinerate the battery, nor to deform the terminal.



RECOMMENDED BATTERY TYPE
G-11-056
 NI-MH 9.6V 1600 mAh

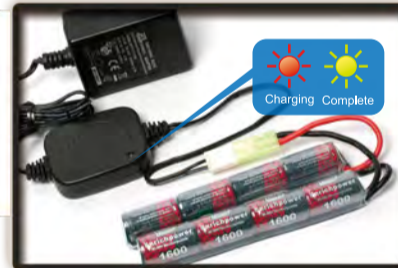

1. Charge up the battery.
 2. Charging will be completed after 3 hours.



Remove the Q.D. sling swivel and sling swivel base. (If attached)



Pull open the handguard slightly with a proper tool.



Move handguard forward to open.

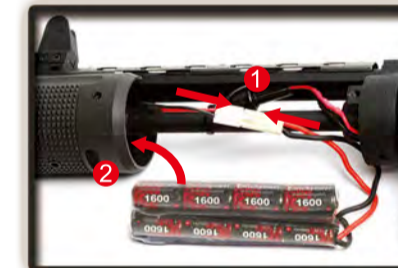

Connect battery plug with the connector then insert the battery into the handguard.



Put the handguard back on.

COMPONENTS

LOADING MAGAZINE

CAUTION

We strongly recommended to use G&G BB pellets only. Using low quality BB pellets will shorten product life and void product warranty.



Open the magazine top plate.



Pour G&G 5.95mm BBs into the chamber and close the plate when the chamber is full.



Turn the winding wheel on the bottom of the magazine to tighten the spring. This will allow the BBs to feed through the top of the magazine.



Insert the magazine into the airsoft gun until it clicks into place.

HOP-UP ADJUSTMENT

CAUTION

Do not catch your fingers in the dummy bolt. Never hold the gun sideways as the BB pellets will curve right or left.



Turn to **Normal** Turn to **Hop**

FIRING MODE & SAFETY



SAFETY ON
 Unable to fire.



SEMI AUTO
 Single shot.



FULL AUTO
 Automatic firing.

- ✗ **Too much Hop-up.** (Turn the adjustment dial toward **Normal** to correct the upward trajectory.)
- **Best Position.**
- ✗ **Not enough Hop-up.** (Turn the adjustment dial toward **Hop** to correct downward trajectory.)



GC300 S/L INSTRUCTION MANUAL



TOP FIVE
FUTURE INNOVATION
FINEST QUALITY
FAST SERVICE
FREE ITEMS
FAIR PRICE

⚠ WARNING !!

- Adult supervision required.
- May be hazardous up to 50 meters.

- Stop shooting when the battery power is low.
- Do not adjust the motor without authorization or by certified technician.
- Always wear eye protection when using this product.
- Misuse or careless handling of this product may cause injury.

- This product is intended for users 18 years or older.
- Read all instructions before using this product.
- The buyer and the user of this product shall adhere to all local laws regulating the usage and the ownership of airsoft guns.

FOLDING STOCK

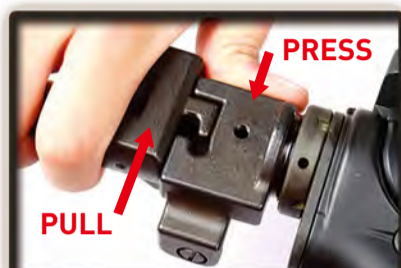

Press the stock base with the thumb and pull up.



Fold the stock to the left side of the gun.

UNJAM



Remove the magazine.

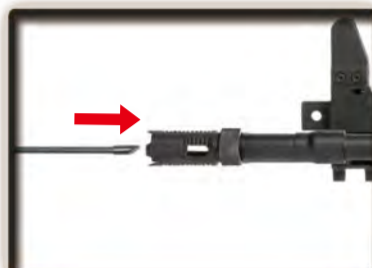

Return the hop up dial to normal position and insert the cleaning rod from the lead edge of the inner barrel.



Be sure to have the rod facing down and reaching to the end to remove clogged pellets.

TROUBLE SHOOTING



Adjust screw when the gear noise becomes shrilly.

Use a screwdriver to adjust the screw at the bottom of the grip.



No operation

Check the wire set contact on the motor.



No operation

Make sure the battery is fully charged and wires are properly connected.

FRONT SIGHT ADJUSTMENT



Use the front sight adjustment tool.

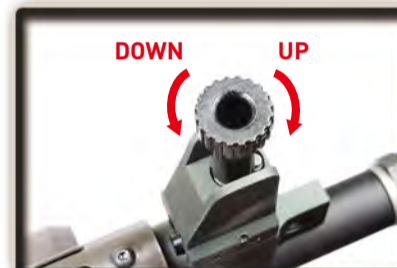

Turning clockwise: To correct high shots. Turning counterclockwise: To correct low shots.

REAR SIGHT ADJUSTMENT



SMALL HOLE
Used for precision firing.



LARGE HOLE
Used for full automatic firing.



WINDAGE KNOB
(left / right adjustment)

MOVABLE PARTS

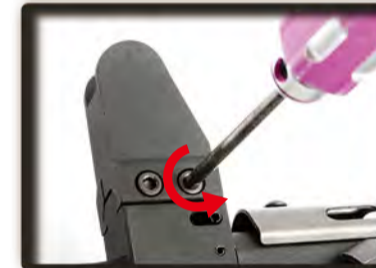

Unscrew and take the fixing screws off to remove the front sight.



Unscrew and take the fixing screws off to remove the rear sight.

PARTS LIST

GC300-01	Flash suppressor set	GC300-14	Dust cover set
GC300-03	Outer barrel set (Long Type)	GC300-15	Lower receiver set
GC300-04	Outer barrel set (Short Type)	GC300-16	Charging handle
GC300-05	Inner barrel (Long Type)	GC300-17	Magazine catch set
GC300-06	Inner barrel (Short Type)	GC300-18	Rear receiver lock pin set
GC300-07	Handguard set	GC300-19	Selector lever set
GC300-08	Hop-Up rubber set	GC300-20	Wire set
GC300-09	Gear box set	GC300-21	Grip bottom plate set
GC300-10	Front sight set	GC300-22	Grip set
GC300-11	Hop-Up set	GC300-23	Motor set
GC300-12	Rear sight set	GC300-24	Magazine
GC300-13	Upper receiver set	GC300-25	Folding stock set

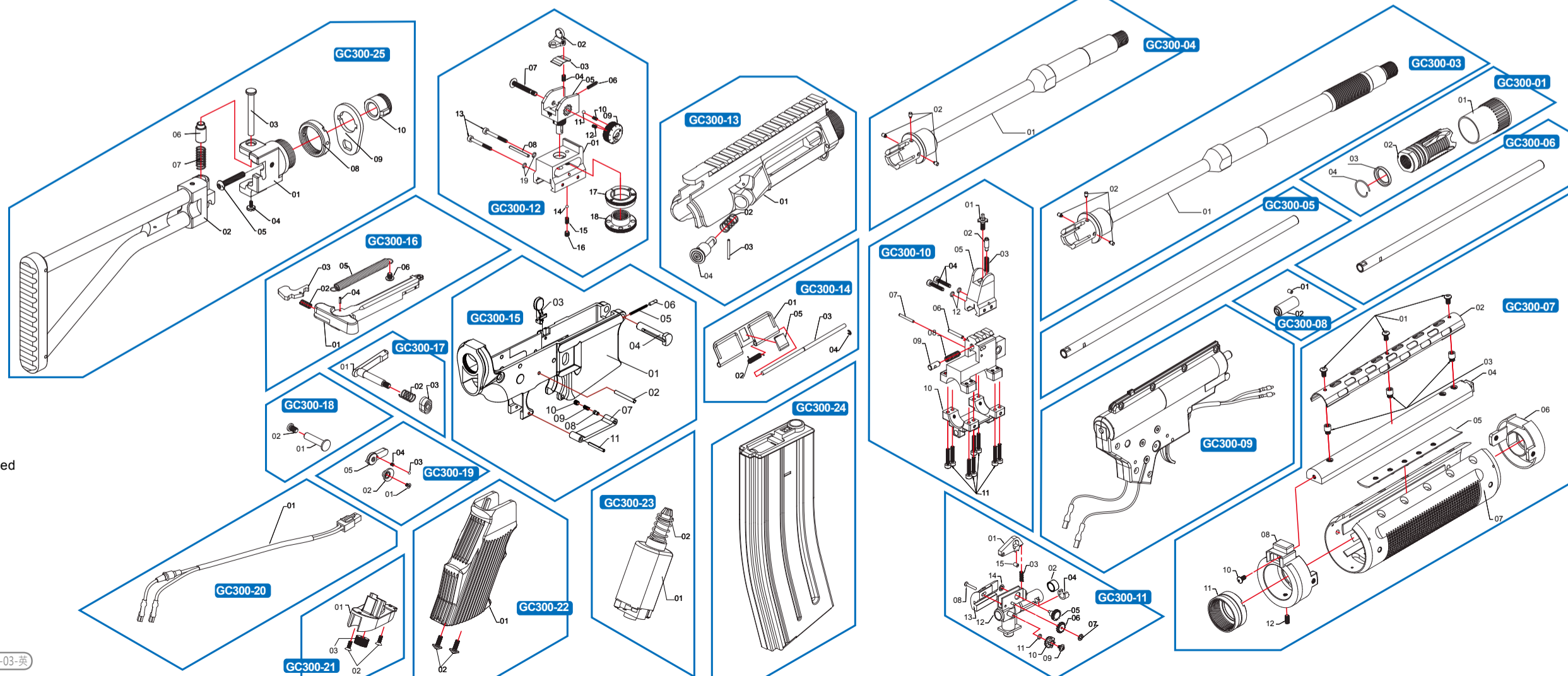

Sales Dept. | sales@guay2.com , b2b@guay2.com
Technology Support Dept. | support@guay2.com
PR Dept. | pr@guay2.com

▶ The grouped parts may all be purchased from the G&G Support Department.

▶ E-Mail: support@guay2.com

Chang Hua Headquarter
Tel : +886-4-798-9000 Fax : +886-4-798-9900
No.999, Zhonghua Rd. Shengang Township, Changhua County 50955, Taiwan (R.O.C.)

Taipei
Tel : +886-2-2692-2000 Fax : +886-2-2692-4000
11F-3., No.27, Lane 169, Kangning St. Shijr City, Taipei County 22180, Taiwan (R.O.C.)

Dealer